

WYPEŁNIA ZESPÓŁ NADZORUJĄCY

KOD UCZNI

--	--	--

PESEL

--	--	--	--	--	--	--	--	--	--	--	--

Miejsce na naklejkę.

Sprawdź, czy kod na naklejce to

O-700.



Egzamin ósmoklasisty

Język angielski

DATA: **25 maja 2023 r.**

GODZINA ROZPOCZĘCIA: **9:00**

CZAS PRACY: **do 135 minut**

Instrukcja dla ucznia

1. Sprawdź, czy na kolejno ponumerowanych **15 stronach** jest wydrukowanych **11 zadań**.
2. Ewentualny brak stron lub inne usterki zgłoś nauczycielowi.
3. Czytaj uważnie wszystkie teksty i zadania.
4. Wykonuj zadania zgodnie z poleceniami.
5. Wszystkie zadania rozwiązuj długopisem lub piórem.
6. W każdym zadaniu poprawna jest zawsze **tylko jedna** odpowiedź.
7. Jeśli się pomylisz, postępuj zgodnie z informacjami zamieszczonymi na następnej stronie.

Powodzenia!

WYPEŁNIA ZESPÓŁ NADZORUJĄCY

Uprawnienia ucznia do dostosowania zasad oceniania.

Uczeń **nie prznosi** odpowiedzi na kartę odpowiedzi.



OJAP-**700**-2305

Zapoznaj się z poniższymi informacjami

1. W niektórych zadaniach musisz wpisać znak **X** w kratkę obok poprawnej odpowiedzi, np.

A. B. C.

Jeśli się pomylisz, otocz kratkę z błędną odpowiedzią kółkiem i wpisz znak X w kratkę obok poprawnej odpowiedzi, np.

A. B. C.

2. W innych zadaniach musisz wpisać w kratkę odpowiednią literę, np.

1. C

Jeśli się pomylisz, otocz kratkę z błędną odpowiedzią kółkiem i napisz obok poprawną odpowiedź, np.

1. C E

3. Jeśli się pomylisz, zapisując odpowiedź w zadaniu otwartym, pomyłkę przekreśl i napisz poprawną odpowiedź nad niepoprawnym fragmentem lub obok niego, np.

a

t	r	e	i	n
---	---	--------------	---	---

goes

The boy (go) going to school by bus.

The boy goes to school by bus. train

Zadanie 1. (0–5)

Przeczytaj teksty. Zdecyduj, czy każde zdanie (1.–5.) jest zgodne z treścią tekstu (TAK albo NIE). Wpisz znak X w odpowiednią kratkę.

**The teacher is ill today!
There is no English class!**

**Next week you will have
an extra lesson on Monday.**

1. The English lesson will be longer today.

TAK

NIE

FITNESS CENTER

HOLIDAY INFO

The gym will be closed
from 1st July.
We will open it for you again
on Monday 1st August.

2. You can train at the gym in July.

TAK

NIE

Na podstawie: stock.adobe.com

ITALIAN WEEK

Only this week:
all pizzas and soups
20% off!

We will be serving Spanish meals
next week.

To order, call: 123 123 123.

3. You can read this text in a restaurant.

TAK

NIE



FIT
Family Day

Do you want to see your daughter or son running, jumping and playing football? Join us for a Fit Family Day!

You can also take part in a special parents & kids competition!

Friday 6th April, 10:30 a.m.
East Lane Primary School

Na podstawie: www.fitnyc.edu



John,

remember about your appointment at 4.30 p.m. You have to leave no later than at 3.30 because there is a lot of traffic today.

4. This text invites people to come to a sports event.

TAK

NIE

5. This text is about a problem with a bike.

TAK

NIE

Zadanie 2. (0–4)

Przeczytaj tekst. Dopasuj do każdej oznaczonej części tekstu odpowiedni nagłówek (A–E). Wpisz odpowiednią literę w każdą kratkę (1.–4.).

Uwaga! Jeden nagłówek został podany dodatkowo i nie pasuje do żadnej części tekstu.

- A. The Queen's travels around the world
- B. Starting a family
- C. One reason – two celebrations
- D. The Queen's favourite place
- E. Becoming Queen

QUEEN ELIZABETH II

Let's take a look at some facts about Queen Elizabeth II.



Na podstawie: pl.pinterest.com

1.

Elizabeth was born on 21 April 1926. She was still a princess when she fell in love with Philip Mountbatten, who became her husband in 1947. A year later their first child was born. It was a boy and they called him Charles. Later Elizabeth and Philip had three more children – two sons and one daughter.

2.

Princess Elizabeth was very young when her father, King George VI, died. She got the information about his death when she was on an official visit to Kenya with her husband Philip. She did not expect to become Queen so early. She was only 25 years old then. Her coronation took place on 2 June 1953 at Westminster Abbey in London.

3.

One of Queen Elizabeth's residences was Balmoral Castle. She spent her summer holidays at the castle where she felt happier than anywhere else in the world. She went for long walks there and relaxed with her family members, who often came to the castle to visit the Queen.

4.

Queen Elizabeth II had two birthdays. She usually spent the real one (21 April) in private with her family. But every year in June there was also a parade in London to celebrate the monarch's official birthday. This tradition was started long ago by King George II.

Zadanie 3. (0–3)

Przeczytaj tekst. Wybierz poprawną odpowiedź. Wpisz znak X w kratkę obok jednej z odpowiedzi: A, B albo C.

A LONDON TAXI DRIVER



Peter Stevens started working as a London taxi driver over 35 years ago. The big city looked different then and many places have changed a lot since then. Also, the traffic was not as heavy as it is today. There were fewer cars and it was easier to move around the city. The job is harder now, but Peter says he still loves it, because he never gets bored.

He enjoys driving around London and talking to his passengers. Tourists often ask him about different attractions in London or recommendations for best restaurants. He's always glad to help. But he has one rule: he never talks about politics or the Royal Family. Passengers are often surprised because he always knows how to get to the right address, but he never uses GPS! For Peter that's easy. When he decided to become a taxi driver, he had to pass a very difficult exam. It took him a lot of time to prepare for it because he had to learn where each street is located in London.

However, there is one thing he doesn't like so much. London at night is not a very safe place, so Peter feels a bit worried when he has to work late. And although he can earn more money at night, and a lot of people need taxis then, he prefers to drive during the day.

Na podstawie: www.vickyfoxcroft.org.uk

1. Thirty-five years ago Peter Stevens

- A. didn't work in London.
- B. had the same job as today.
- C. changed his job because he was bored.

2. When Peter drives his taxi, he often

- A. has to use GPS to get to places.
- B. tells stories about the Royal Family.
- C. gives passengers advice about where to eat.

3. Peter doesn't like to work at night because

- A. it is less safe.
- B. he gets less money.
- C. there are not many passengers.

Zadanie 4. (0–4)

Przeczytaj tekst. Uzupełnij go brakującymi fragmentami zdań (A–E). Wpisz odpowiednią literę w każdą kratkę (1.–4.).

Uwaga! Jeden fragment zdania został podany dodatkowo i nie pasuje do tekstu.

MARK'S BLOG 🔍

Guess what happened to me 1. from school a few days ago. While I was walking through the park, I saw something under a large tree. It was getting dark, so I 2. what it was. I decided to walk up to the tree, and I 3. which started to play with me. It looked 4. I took it home.

My mother was not very happy but she let me keep it anyway.









- A. most of my free time
- B. so cute that
- C. couldn't see clearly
- D. found a small cat
- E. on my way back

Zadanie 5. (0–5)

Uzupełnij każdą rozmowę brakującą wypowiedzią (A–F). Wpisz odpowiednią literę w każdą kratkę (1.–5.).

Uwaga! Jedna wypowiedź została podana dodatkowo i nie pasuje do żadnej rozmowy.

- A. A fascinating article about my football team.
- B. Yes, they are great!
- C. I'll just have the soup, please.
- D. I promise I will bring you the book.
- E. I agree. This comedy is really boring.
- F. Thanks, but we both played really well.

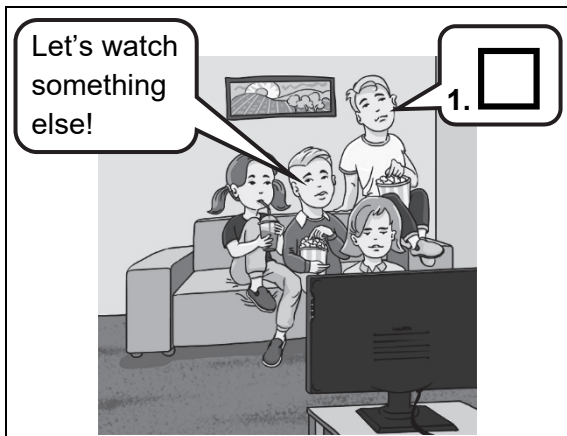

Zadanie 6. (0–5)

Uzupełnij każdy dialog brakującą wypowiedzią, tak aby otrzymać spójne i logiczne teksty. Wpisz znak X w kratkę obok jednej z odpowiedzi: A albo B.

1. **X:** How do you get to school?

Y: _____

A. I usually walk.

B. My teachers are nice.

2. **X:** I'm really tired today.

Y: _____

A. You should go to bed early.

B. I went to the doctor.

3. **X:** Could you open the door, please?

Y: _____

A. Sure, no problem.

B. No, it's not open.

4. **X:** Excuse me, where is the nearest bus stop?

Y: _____

A. You'll get a new one.

B. I'll show you on the map.

5. **X:** How about going for a pizza?

Y: _____

A. OK, great idea.

B. Sorry, I can't cook.

Zadanie 7. (0–5)

Dla każdej z opisanych sytuacji wybierz właściwą reakcję. Wpisz znak X w kratkę obok jednej z odpowiedzi: A, B albo C.

1. Chcesz kupić słownik. Co powiesz sprzedawcy?

A. Can I return these dictionaries?

B. Did you pay much for this dictionary?

C. Do you have any dictionaries?

2. Jak zaproponujesz koleżance wspólne wyjście do zoo?

A. What animals do you like?

B. Where is the zoo in this town?

C. Why don't we go to the zoo?

3. Kolega kupił sobie nowe spodnie. Jak powiesz, że Ci się podobają?

A. I like your new trousers.

B. I like shopping for trousers.

C. I'd like to buy some new trousers.

4. Twój kolega chciałby zacząć uczyć się nowego języka obcego. Co mu poradzisz?

A. I think you should learn Spanish.

B. I like our new English teacher.

C. I have never been to a language school.

5. Chcesz pożyczyć od kolegi plecak. Co powiesz?

A. Is it a good idea to buy a new backpack?

B. Have you seen my new backpack?

C. Could you lend me your backpack?

Zadanie 8. (0–5)

Przeczytaj opis ilustracji. Uzupełnij luki w tekście, tak aby był on poprawny i zgodny z ilustracją. Wpisz znak X w kratkę obok jednej z odpowiedzi: A albo B.



Na podstawie: www.desparasitaatumascota.es

1. _____ two people with a dog in the picture. They are 2. _____ in a forest. They are both wearing jackets and the woman has a long 3. _____ around her neck. They look 4. _____. Probably it is autumn because there are a lot of 5. _____ on the ground.

1.

A. It is

B. There are

2.

A. sitting

B. walking

3.

A. scarf

B. hat

4.

A. relaxed

B. worried

5.

A. flowers

B. leaves

Zadanie 9. (0–6)

Co przedstawiają obrazki? Wpisz w kratki brakujące litery.

1.



w					w
---	--	--	--	--	---

2.

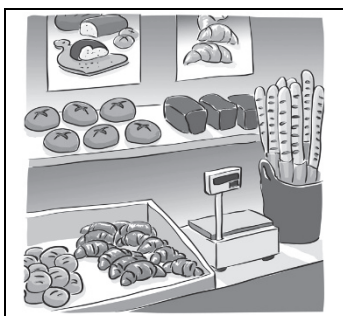

b					y
---	--	--	--	--	---

3.



s						n
---	--	--	--	--	--	---

4.

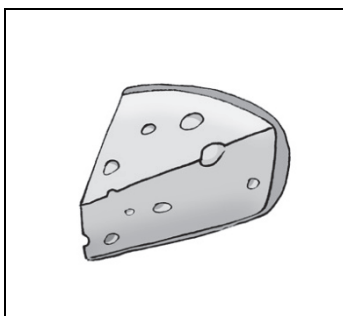

c					e
---	--	--	--	--	---

5.



p			c		
---	--	--	---	--	--

6.

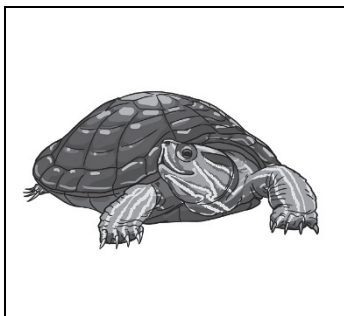

t					e
---	--	--	--	--	---

Zadanie 10. (0–3)

Wpisz we właściwej formie wyraz podany w nawiasie.

1. My brother (**get**) _____ a new watch for his last birthday.
2. Julie looked after (**Robert**) _____ dog when he was on holiday.
3. How many (**day**) _____ are you going to spend in London?

Zadanie 11. (0–10)

Opisz ilustrację, odpowiadając na podane pytania pełnymi zdaniami w języku angielskim. W pytaniu 5. nie musisz udzielać prawdziwej odpowiedzi – możesz ją wymyślić.



Na podstawie: www.careeraddict.com

1. Who is the woman in the photo?

2. Where are the children?

3. What is the woman wearing?

4. Why do the children have their hands up?

5. What is your favourite subject? Why?
