

UZUPEŁNIA ZESPÓŁ NADZORUJĄCY

KOD UCZNI

--	--	--

PESEL

--	--	--	--	--	--	--	--	--	--	--

*miejsce
na naklejkę*

SPRAWDZIAN W KLASIE SZÓSTEJ SZKOŁY PODSTAWOWEJ

CZĘŚĆ 2. JĘZYK ANGIELSKI

**UZUPEŁNIA ZESPÓŁ
NADZORUJĄCY**

Uprawnienia ucznia
do nieprzenoszenia
zaznaczeń na kartę

Instrukcja dla ucznia

1. Sprawdź, czy na kolejno ponumerowanych 11 stronach jest wydrukowanych **9 zadań**. Ewentualny brak stron lub inne usterki zgłoś nauczycielowi.
2. Wszystkie zadania rozwiąż długopisem lub piórem.
3. Czytaj uważnie wszystkie teksty i zadania.
4. Wykonuj zadania zgodnie z poleceniami.
5. W każdym zadaniu jest tylko jedna poprawna odpowiedź.

W niektórych zadaniach musisz wpisać znak **X** w kratkę obok poprawnej odpowiedzi, np.

A. B. C.

W innych zadaniach musisz wpisać w kratkę odpowiednią literę, np.

1. C

6. Jeśli się pomylisz, otocz kratkę z błędną odpowiedzią kółkiem i podaj inną odpowiedź, np.

A. B. C.

albo

1. C *E*

**5 KWIETNIA
2016**

**Godzina rozpoczęcia:
11:45**

**Czas pracy:
do 70 minut**

Powodzenia!



SA-7-162

Zadanie 1. (0–4)

Uzupełnij każdą rozmowę brakującą wypowiedzią (A–D). Wpisz odpowiednią literę w każdą kratkę (1.–4.).

- A. I like comic books.
- B. He's my brother, Jim.
- C. Just two maths exercises.
- D. OK, but put on your raincoat, please. It's raining.

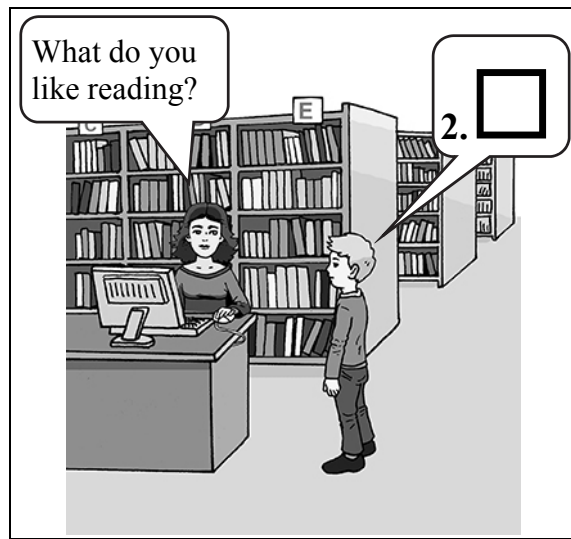

Zadanie 2. (0–4)

Dla każdej z opisanych sytuacji wybierz właściwą reakcję. Wpisz znak X w kratkę obok odpowiedzi A albo B.

1. Zapytaj kolegę o imię jego mamy.

A. What's your mother's name?

B. How old is your mother?

2. Powiedz koleżance, że podoba Ci się jej sukienka.

A. Buy a new dress.

B. I like your new dress.

3. Poproś koleżankę, żeby Cię odwiedziła.

A. Please come to visit me this summer.

B. Summer is beautiful this year.

4. Wygrałeś / wygrałeś szkolny konkurs. Co powiesz?

A. Have a nice day!

B. I'm so happy!

Zadanie 3. (0-5)

W każdej kategorii wybierz słowo, które do niej NIE pasuje. Wpisz znak X w kratkę obok odpowiedzi A, B albo C.

1. Pogoda:

A. snowy

B. lazy

C. windy

2. Części ciała:

A. nose

B. hand

C. pencil

3. Środki transportu:

A. bag

B. ship

C. plane

4. Kolory:

A. red

B. white

C. picture

5. Członkowie rodziny:

A. uncle

B. plate

C. grandpa

Zadanie 4. (0–6)

Popatrz na rysunek. Zdecyduj, czy podane zdania są zgodne z rysunkiem (TAK albo NIE). Wpisz znak X w odpowiednią kratkę.



1. It's a sunny day.

TAK	<input type="checkbox"/>	NIE	<input type="checkbox"/>
-----	--------------------------	-----	--------------------------

2. The people are in the city.

TAK	<input type="checkbox"/>	NIE	<input type="checkbox"/>
-----	--------------------------	-----	--------------------------

3. The boy is playing with a dog.

TAK	<input type="checkbox"/>	NIE	<input type="checkbox"/>
-----	--------------------------	-----	--------------------------

4. The woman is taking a photo.

TAK	<input type="checkbox"/>	NIE	<input type="checkbox"/>
-----	--------------------------	-----	--------------------------

5. The girl is riding a bike.

TAK	<input type="checkbox"/>	NIE	<input type="checkbox"/>
-----	--------------------------	-----	--------------------------

6. The man has a backpack in his hand.

TAK	<input type="checkbox"/>	NIE	<input type="checkbox"/>
-----	--------------------------	-----	--------------------------

Zadanie 5. (0-5)

Co jest na rysunkach (1.-5.)? Wpisz odpowiednią literę (A-E) w każdą kratkę.

A. sharpener	B. ruler	C. rubber	D. pencil case	E. pen
--------------	----------	-----------	----------------	--------

1.

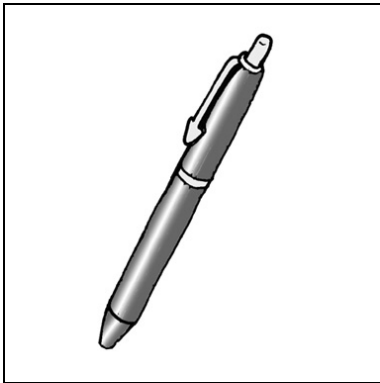

2.

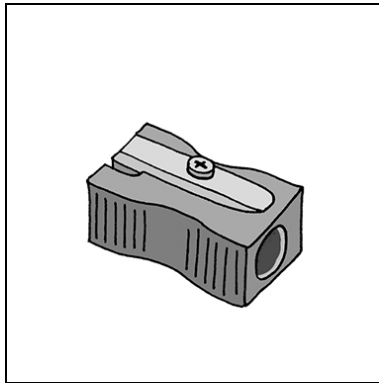

3.

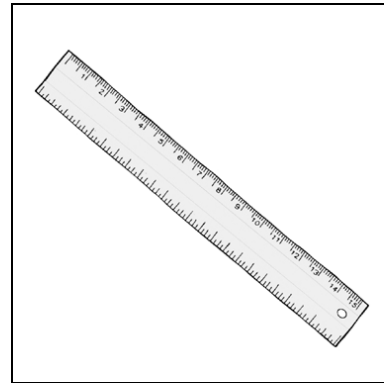

4.

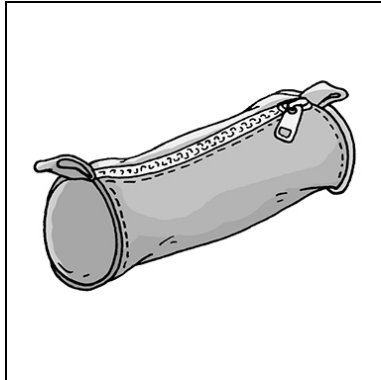

5.

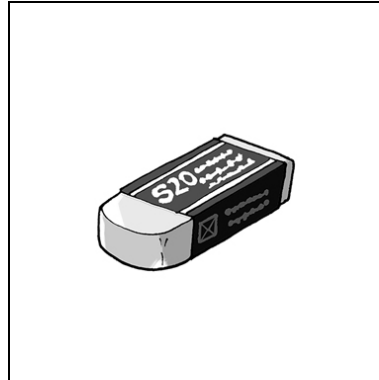

Zadanie 6. (0–4)

Gdzie przeczytasz te teksty? Wpisz odpowiednią literę (A–D) w każdą kratkę (1.–4.).

1.

Information for patients

Dr Johnson
Monday – Thursday
8 a.m. – 2 p.m.
Dr Wilson
Tuesday – Friday
11 a.m. – 4 p.m.

2.

Tomorrow is *Sports Day*.
All classes finish lessons
at 11.30 a.m.

3.

“OLD CARS”
ENTRY TICKETS

Children	£1
Students	£1.50
Adults	£3
Groups (10 people or more)	£10

Opening hours:
Tuesday – Saturday
9 a.m. – 5 p.m.

4.

SNOWBOARDS
NEW AND SECOND-HAND
BUY HERE

Monday – Saturday
8 a.m. – 6 p.m.
Sunday – closed

- A. in a shop
- B. in a school
- C. in a hospital
- D. in a museum

Zadanie 7. (0–4)

Zdecyduj, o kim/o czym jest każdy tekst (1.–4.). Wpisz odpowiednią literę (A–D) w każdą kratkę.

A. a match	B. a friend	C. a room	D. a teacher
------------	-------------	-----------	--------------

1.

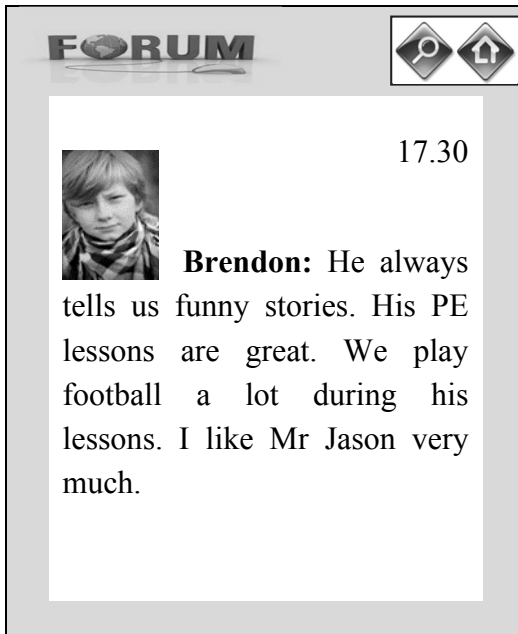

FORUM  

 17.30

Brendon: He always tells us funny stories. His PE lessons are great. We play football a lot during his lessons. I like Mr Jason very much.

This text is about .

2.

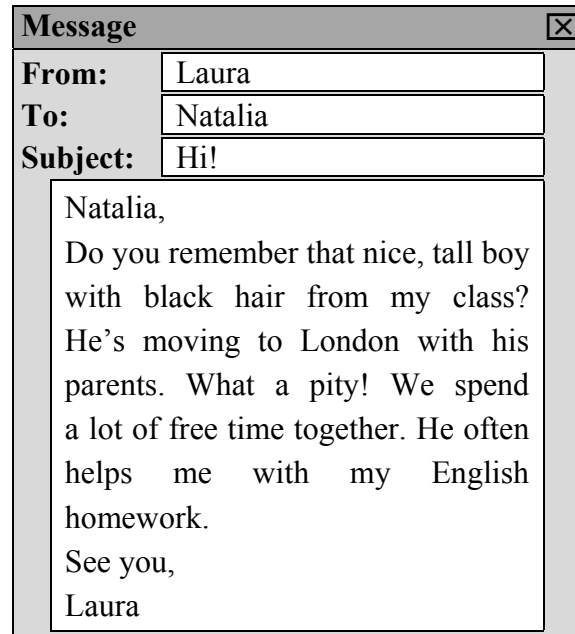

Message 

From: Laura

To: Natalia

Subject: Hi!

Natalia,
Do you remember that nice, tall boy with black hair from my class? He's moving to London with his parents. What a pity! We spend a lot of free time together. He often helps me with my English homework.
See you,
Laura

This text is about .

3.

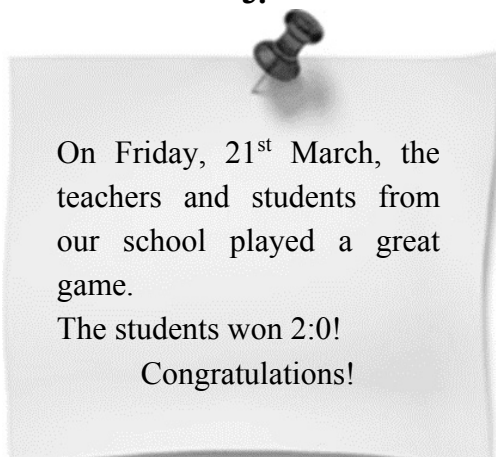

On Friday, 21st March, the teachers and students from our school played a great game.
The students won 2:0!
Congratulations!

This text is about .

4.

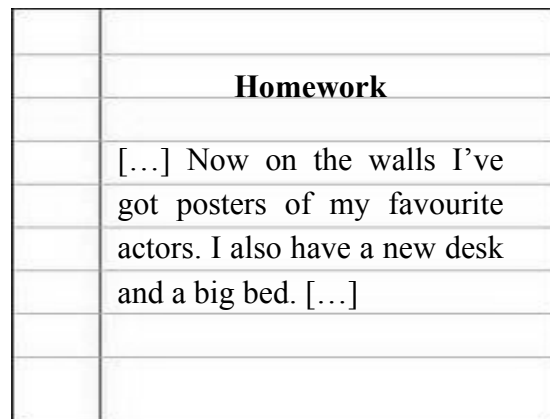

	Homework
	[...] Now on the walls I've got posters of my favourite actors. I also have a new desk and a big bed. [...]

This text is about .

Zadanie 8. (0–5)

Przeczytaj tekst. Zdecyduj, czy podane zdania są zgodne z treścią tekstu (TAK albo NIE). Wpisz znak X w odpowiednią kratkę.

Dear Monica,

I had a busy day today. Do you remember my grandparents? Last winter you and I stayed at their house in the mountains. Grandpa taught us to ski.

You know every summer my grandparents visit us because they love the seaside. They usually come all the way from the mountains on the train. But today Grandma surprised us all. She came alone on her motorbike! Grandpa couldn't come because he didn't feel well.

My brother Paul is crazy about motorbikes and he liked Grandma's new, fast motorbike very much. He was really happy when Grandma took him for a ride on it. He even asked his friends to see Grandma's motorbike. They loved it!

Love from Laura

1. Laura's grandparents live in the mountains.

TAK

NIE

2. Grandpa came on his motorbike with Grandma.

TAK

NIE

3. Laura is Paul's sister.

TAK

NIE

4. Grandma's motorbike is old.

TAK

NIE

5. Paul's friends saw Grandma's motorbike.

TAK

NIE

Zadanie 9. (0–3)

Przeczytaj tekst. Wybierz poprawną odpowiedź. Wpisz znak X w kratkę obok odpowiedzi A, B albo C.

LAYLA'S DIARY

Tuesday, March 20th

Dear Diary,

Yesterday I was very happy. There were no lessons and we didn't have to go to the swimming pool in the afternoon. Instead, we went with our teacher to the zoo. We went there by bus. We saw tigers, giraffes, lions, monkeys and many other interesting animals.

At one o'clock we had a lunch break. Then at two o'clock, a famous traveller, Jake Rowson, showed us a film about his journey to Africa. It was amazing.

At the end of our visit every student got a small gift. It was a toy animal. I wanted to get a monkey but I got a tiger.

I was back home at four o'clock. I had a great time at the zoo.

1. Where did the girl go yesterday?

A.

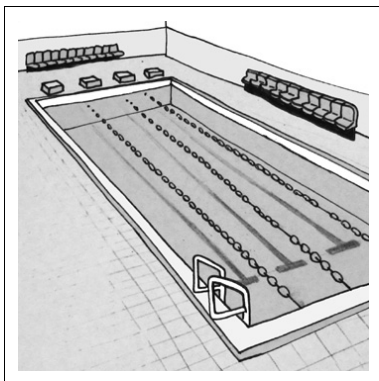

B.

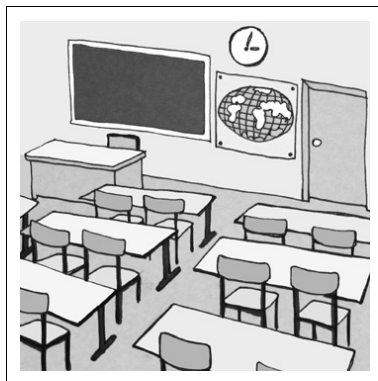

C.

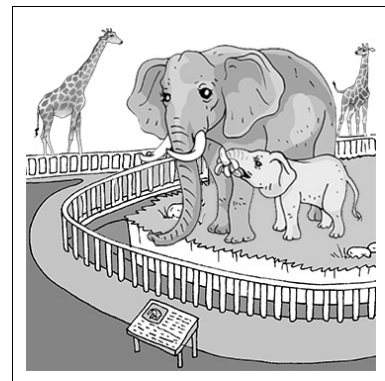

Ciąg dalszy zadania 9. znajduje się na następnej stronie.

2. What time did the girl watch the film?

A.



B.



C.



3. What present did the girl get?

A.



B.

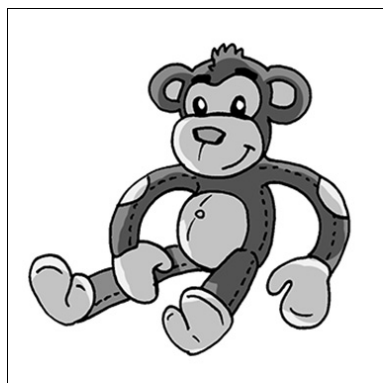

C.

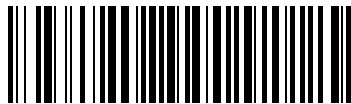

WYPEŁNIA ZESPÓŁ NADZORUJĄCY

 KOD UCZNIKA

--	--	--

 PESEL

--	--	--	--	--	--	--	--	--	--	--	--	--	--	--	--	--	--	--	--

Miejsce na naklejkę

WYPEŁNIA EGZAMINATOR

Nr zad.	Odpowiedzi				
1.1	<input type="checkbox"/> A	<input type="checkbox"/> B	<input type="checkbox"/> C	<input type="checkbox"/> D	
1.2	<input type="checkbox"/> A	<input type="checkbox"/> B	<input type="checkbox"/> C	<input type="checkbox"/> D	
1.3	<input type="checkbox"/> A	<input type="checkbox"/> B	<input type="checkbox"/> C	<input type="checkbox"/> D	
1.4	<input type="checkbox"/> A	<input type="checkbox"/> B	<input type="checkbox"/> C	<input type="checkbox"/> D	
2.1	<input type="checkbox"/> A	<input type="checkbox"/> B			
2.2	<input type="checkbox"/> A	<input type="checkbox"/> B			
2.3	<input type="checkbox"/> A	<input type="checkbox"/> B			
2.4	<input type="checkbox"/> A	<input type="checkbox"/> B			
3.1	<input type="checkbox"/> A	<input type="checkbox"/> B	<input type="checkbox"/> C		
3.2	<input type="checkbox"/> A	<input type="checkbox"/> B	<input type="checkbox"/> C		
3.3	<input type="checkbox"/> A	<input type="checkbox"/> B	<input type="checkbox"/> C		
3.4	<input type="checkbox"/> A	<input type="checkbox"/> B	<input type="checkbox"/> C		
3.5	<input type="checkbox"/> A	<input type="checkbox"/> B	<input type="checkbox"/> C		
4.1	<input type="checkbox"/> T	<input type="checkbox"/> N			
4.2	<input type="checkbox"/> T	<input type="checkbox"/> N			
4.3	<input type="checkbox"/> T	<input type="checkbox"/> N			
4.4	<input type="checkbox"/> T	<input type="checkbox"/> N			
4.5	<input type="checkbox"/> T	<input type="checkbox"/> N			
4.6	<input type="checkbox"/> T	<input type="checkbox"/> N			
5.1	<input type="checkbox"/> A	<input type="checkbox"/> B	<input type="checkbox"/> C	<input type="checkbox"/> D	<input type="checkbox"/> E
5.2	<input type="checkbox"/> A	<input type="checkbox"/> B	<input type="checkbox"/> C	<input type="checkbox"/> D	<input type="checkbox"/> E
5.3	<input type="checkbox"/> A	<input type="checkbox"/> B	<input type="checkbox"/> C	<input type="checkbox"/> D	<input type="checkbox"/> E
5.4	<input type="checkbox"/> A	<input type="checkbox"/> B	<input type="checkbox"/> C	<input type="checkbox"/> D	<input type="checkbox"/> E
5.5	<input type="checkbox"/> A	<input type="checkbox"/> B	<input type="checkbox"/> C	<input type="checkbox"/> D	<input type="checkbox"/> E

Nr zad.	Odpowiedzi			
6.1	<input type="checkbox"/> A	<input type="checkbox"/> B	<input type="checkbox"/> C	<input type="checkbox"/> D
6.2	<input type="checkbox"/> A	<input type="checkbox"/> B	<input type="checkbox"/> C	<input type="checkbox"/> D
6.3	<input type="checkbox"/> A	<input type="checkbox"/> B	<input type="checkbox"/> C	<input type="checkbox"/> D
6.4	<input type="checkbox"/> A	<input type="checkbox"/> B	<input type="checkbox"/> C	<input type="checkbox"/> D
7.1	<input type="checkbox"/> A	<input type="checkbox"/> B	<input type="checkbox"/> C	<input type="checkbox"/> D
7.2	<input type="checkbox"/> A	<input type="checkbox"/> B	<input type="checkbox"/> C	<input type="checkbox"/> D
7.3	<input type="checkbox"/> A	<input type="checkbox"/> B	<input type="checkbox"/> C	<input type="checkbox"/> D
7.4	<input type="checkbox"/> A	<input type="checkbox"/> B	<input type="checkbox"/> C	<input type="checkbox"/> D
8.1	<input type="checkbox"/> T	<input type="checkbox"/> N		
8.2	<input type="checkbox"/> T	<input type="checkbox"/> N		
8.3	<input type="checkbox"/> T	<input type="checkbox"/> N		
8.4	<input type="checkbox"/> T	<input type="checkbox"/> N		
8.5	<input type="checkbox"/> T	<input type="checkbox"/> N		
9.1	<input type="checkbox"/> A	<input type="checkbox"/> B	<input type="checkbox"/> C	
9.2	<input type="checkbox"/> A	<input type="checkbox"/> B	<input type="checkbox"/> C	
9.3	<input type="checkbox"/> A	<input type="checkbox"/> B	<input type="checkbox"/> C	



--	--	--	--	--	--	--	--	--

KOD EGZAMINATORA

.....
Czytelny podpis egzaminatora